

CAPACITY	SYMBOL/ SERIAL NO.	CIRCUIT DIAGRAM
AC 230V		
65W x 1		

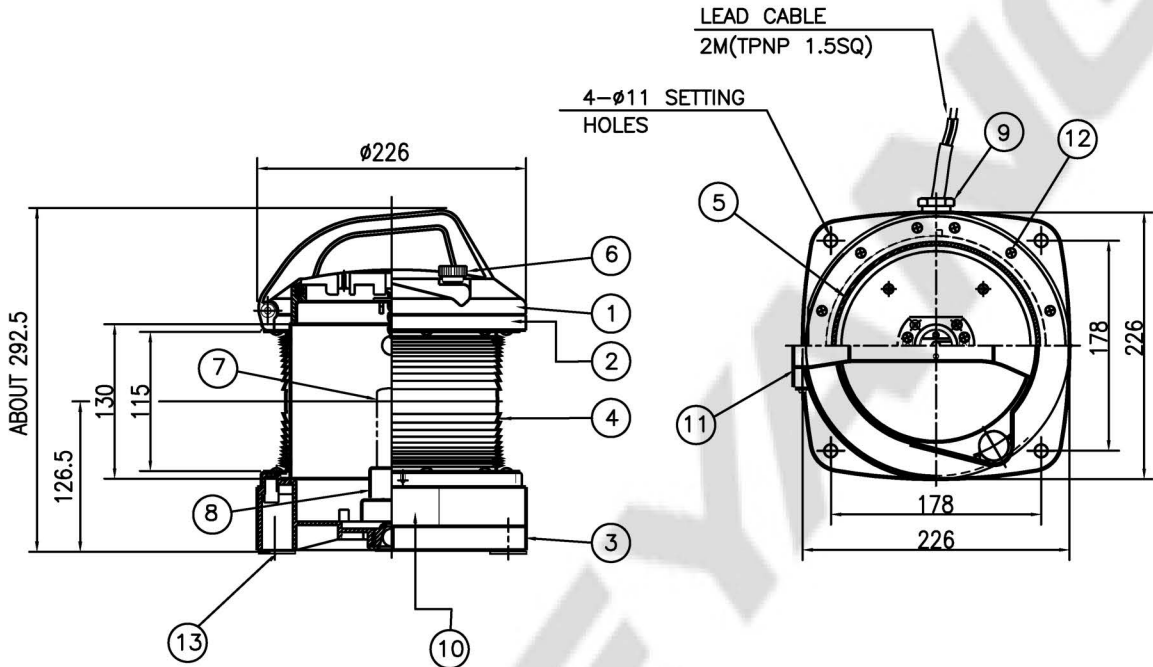

NOTE

1. APPLICATION RANGE : VESSEL OF 50M IN LENGTH AND ABOVE
2. MINIMUM VISIBILITY : 3 N.M

*** CAUTION!!**

Do not install the navigation light upside down.
Since breathing device is installed on the bottom of fixture.

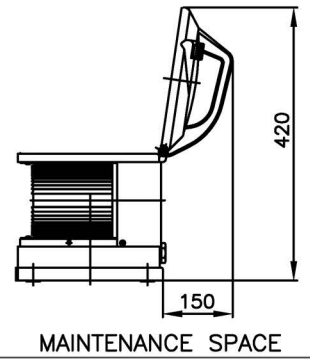

NO	NAME OF PARTS	MATERIAL	Q'TY	REMARKS	NO	NAME OF PARTS	MATERIAL	Q'TY	REMARKS
13	ANTI-VIBRATION PACKING	C.R.	4	5mm	7	NAVIGATION LIGHT LAMP	-	1	P28s
12	T/H TAPPING SCREW	STAINLESS STEEL 304	24	M4	6	CLAMP BOLT	BRASS	2	
11	HINGE	POLYCAR-BONATE	1		5	GASKET	SILICONE RUBBER	1	
10	NAME PLATE	STAINLESS STEEL 316L	1		4	LENS	POLYCAR-BONATE	1	DARK CLEAR
9	CABLE GLAND(#20)	NYLON	1	ø12~ø15	3	BODY	POLYCAR-BONATE	1	
8	LAMP HOLDER	PPS	1	P28s	2	TOPPER	POLYCAR-BONATE	1	
					1	COVER	POLYCAR-BONATE	1	

APPROVED	B. K. KIM	UNIT	MM	TITLE; WHITE LIGHT FOR MARINE USE			
CHECKED		SCALE	N/S				
DRAWING	B. I. KIM	COLOR	MAT BLACK				
DATE	2015.12.04	IP	56				
				MODEL NO.	A2P-SW6523Hh-1.5M-MED	WEIGHT	2.9 Kg
				DWG NO.	L31150092	SHEET NO.	31